

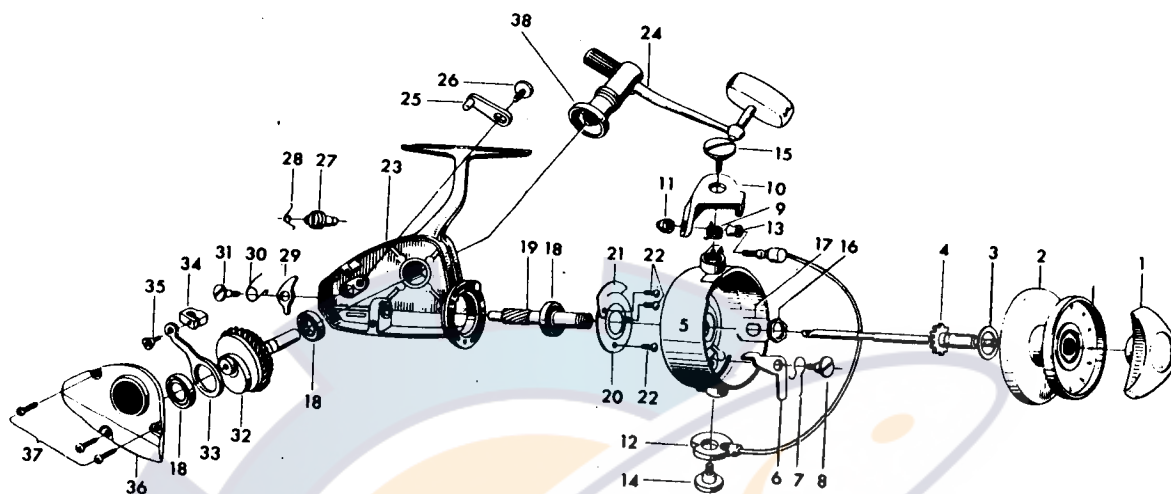

SPINNING REEL 8600A



LINE CAPACITY: 270 YDS., 15 LB. TEST (210m Dia. 0.40mm)

Key No.	Parts No.	Parts Name	Key No.	Parts No.	Parts Name
1	60008232	Drag knob	20	66323201	Ball bearing retaining washer
2	67305511	Spool assembly	21	61506001	Cushion spring
3	63726503	Spool washer	22	63516101	Ball bearing ret. washer screw
4	60007931	Main shaft	23	60013222	Body
5	60013541	Rotor	24	67456701	Handle
6	65704101	Bail kick lever	25	65404521	Anti-reverse lever
7	61405031	Bail kick lever spring	26	63501931	Anti-reverse lever screw
8	63612901	Bail kick lever screw	27	64604001	Anti-reverse cam
9	61416411	Bail spring	28	61417321	Anti-reverse cam spring
10	62304611	Arm lever	29	61104511	Anti-reverse claw
11	63408501	Bail nut	30	61416301	Anti-reverse claw spring
12	60002631	Bail	31	63613801	Anti-reverse claw screw
13	62501501	Line roller	32	60007721	Drive gear
14	63612801	Bail holder screw	33	64804011	Oscillating slider
15	63613401	Arm lever screw	34	66323301	Oscillating support
16	63404601	Rotor nut	35	63613301	Oscillating support screw
17	63724901	Rotor retaining washer	36	60014502	Body cover
18	66317611	Ball bearing	37	63516401	Body cover screw (3 pcs.)
19	64009842	Pinion	38	66357101	Handle cover